

Allison Torqmatic™

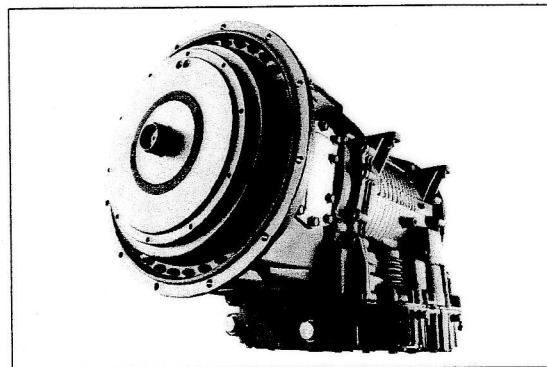

T280 (R) specification

For Applications with engines up to 194 kW (260 hp) gross input power and up to 1000 N•m (738 lb-ft) gross input torque.

RATINGS

	Input Torque Gross N•m (lb-ft)	Input Power Gross ¹ Kw (hp)	Turbine Torque Net ² N•m (lb-ft)	GVW kg (lbs)	Vocations
City Bus	1000 (738)	194 (260)	1857 (1370)	24,000 (52,911)	City Bus
Tour Coach	1000 (738)	194 (260)	1857 (1370)	24,000 (52,911)	Tour Coach

1. Gross Power rating as defined by ISO 1585 or SAE J1995. 2. Turbine Torque limit based on ISCAAN standard deductions.

DRIVETRAIN INTERFACES

Acceptable full-load engine governed speed	2000 – 2800 rpm
Acceptable engine idle speed range (with transmission in Drive)	500 – 800 rpm
Maximum output shaft speed at 105 km/hr (65 mi/hr) – retarder-equipped models only	3600 rpm

MOUNTING

To Engine	SAE No.2
In Chassis	Rear support available (required for some installations)

TORQUE CONVERTER

Type One stage, three element, polyphase.
Includes standard integral damper which is operational in lockup.

Model	Stall Torque Ratio
TC-411	2.71
TC-413	2.44
TC-415	2.35
TC-417	2.20
TC-418	1.98
TC-419	2.02
TC-421	1.77

MECHANICAL RATIOS (Gear ratios do not include torque converter multiplication)

Range

First	3.49 : 1
Second	1.86 : 1
Third	1.41 : 1
Fourth	1.00 : 1
Fifth	0.75 : 1
Sixth	0.65 : 1
Reverse	-5.03 : 1

CONTROL SYSTEM

Description	Allison 4th Generation Electronic Controls with closed loop adaptive shifts								
Shift Sequences	[C = Converter mode (lockup clutch disengaged); L = Lockup mode (lockup clutch engaged)]								
	<table border="0"> <tr> <td>City Bus</td> <td>Tour Coach</td> </tr> <tr> <td>Standard: 1C-[1L]-2C-2L-3L-4L-5L</td> <td>Standard: 1C-[1L]-2C-2L-3L-4L-5L</td> </tr> <tr> <td>Optional: 1C-[1L]-2C-2L-3L-4L-5L-6L</td> <td>Optional: 1C-[1L]-2C-2L-3L-4L-5L-6L</td> </tr> <tr> <td>Optional: 1C-[1L]-2C-2L-3L-4L</td> <td>Optional: 1C-[1L]-2C-2L-3L-4L</td> </tr> </table>	City Bus	Tour Coach	Standard: 1C-[1L]-2C-2L-3L-4L-5L	Standard: 1C-[1L]-2C-2L-3L-4L-5L	Optional: 1C-[1L]-2C-2L-3L-4L-5L-6L	Optional: 1C-[1L]-2C-2L-3L-4L-5L-6L	Optional: 1C-[1L]-2C-2L-3L-4L	Optional: 1C-[1L]-2C-2L-3L-4L
City Bus	Tour Coach								
Standard: 1C-[1L]-2C-2L-3L-4L-5L	Standard: 1C-[1L]-2C-2L-3L-4L-5L								
Optional: 1C-[1L]-2C-2L-3L-4L-5L-6L	Optional: 1C-[1L]-2C-2L-3L-4L-5L-6L								
Optional: 1C-[1L]-2C-2L-3L-4L	Optional: 1C-[1L]-2C-2L-3L-4L								
TCM must be calibrated for "1L" option. Second-gear-start calibrations are not available for all vehicle applications.									
Driver-to-Transmission Interface	Cab-mounted shift selector, pushbutton or lever with two-digit display (range selected and range attained)								
Communication Protocol - Engine/Vehicle Systems Interface	SAE J1939, SAE J1587, ISO 9141, IESCAN								

PHYSICAL DESCRIPTION	Installation length*	Dry weight	Depth below transmission centerline	
			With Shallow Oil Sump (Standard)	With Deep Oil Sump (Optional)
Basic Model	740 mm (29.0 in)	243 kg (535 lbs)	283 mm (11.5 in)	328 mm (12.9 in)
With Retarder	740 mm (29.0 in)	280 kg (615 lbs)	283 mm (11.5 in)	328 mm (12.9 in)

*Approximate length from engine housing to output flange (depending on output flange type)

OUTPUT RETARDER PROVISION (OPTION)			OIL SYSTEM	
Type	Integral, hydraulic		Oil type	Transynd™, DEXRON®-III
Capacity			Capacity, excluding external circuits	
	Torque	Power	With Deep Oil Sump	27 litres (29 quarts)
Level 2	1760 N•m (1300 lb-ft)	373 kW (500 hp)	With Shallow Oil Sump	25 litres (26 quarts)
Level 1	1490 N•m (1100 lb-ft)	298 kW (400 hp)	Main circuit oil filter	Replaceable element, integral
			Cooler circuit oil filter	Replaceable element, integral
			Electronic oil level sensor (OLS)	Standard

SPEEDOMETER PROVISION		TACHOGRAPH PROVISION	
Description	Non-zero-crossing square wave	Tone wheel	4 or 6-tooth
	8, 16 or 40 pulses per revolution of transmission output shaft	Mounting	M18 x 1.5 metric thread
Location	Electronic output from TCM	Location	Transmission rear cover or retarder housing

T280

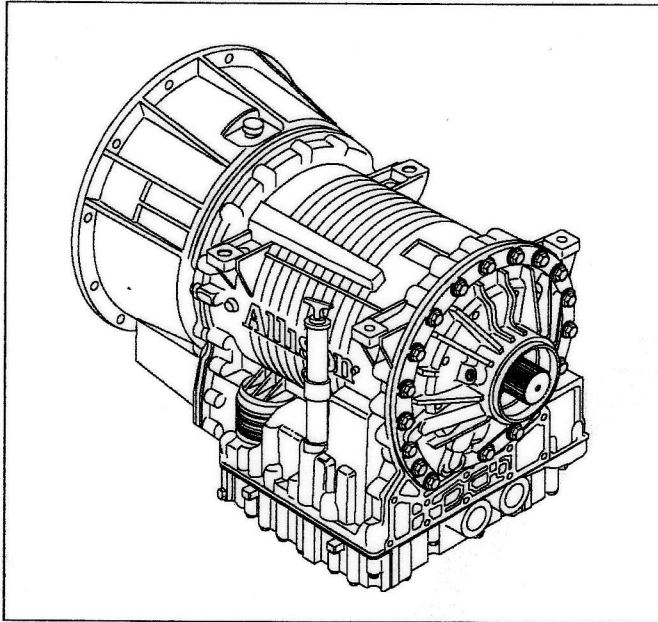

T280 (R)

